

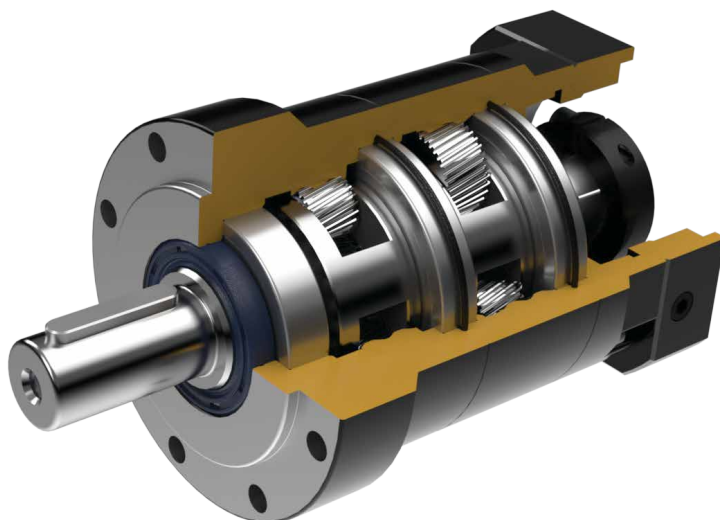

SN series

- 1-Stage Backlash ≤ 6 arcmin
- 2-Stage Backlash ≤ 10 arcmin



Indication of Model Numbers

SN	80	—	10		—	MOTOR
Type	Model		Ratio	Output Shaft Keyway		Motor Type
SN	40		1-Stage 3,	<input type="checkbox"/>		
SNL	50		4, 5, 7, 10	Standard (Keyway)		
	60		2-Stage	N:		
	70		15, 20, 25, 30,	Solid Output Shaft		
	80		35, 40, 50, 70, 100	(No Keyway)		
	90					
	115					
	120					
	155					
	160					

Quiet operation

Grinding spiral bevel gear & Helical gears contribute to reduce vibration and noise.

High Rigidity & High Torque

High rigidity & high torque are achieved by integrant needle roller bearings and one-piece constructed.

High Efficiency

Efficiency for 1-stage model exceeds 95%; 2-stage model exceeds 92%.

Features of SN Series

SN



Helical Gear Design

The speed reduction mechanism employs helical gears, which provides two times meshing rate of teeth when comparing with regular spur gears. In addition, it also features extremely smooth running, low noise, high torque output and low backlash.

High Precision Gear Machining

Manufactured from high quality Ni-Cr-Mo alloy steel (SNM220), precision achined and carburized to hardness 57-60 HRC. Precision teeth grinding sure gear accuracy reaches DIN6 class.



Integrated Planetary Arm Bracket

The planetary arm bracket and the output shaft are one-piece constructed to increase torsional rigidity and accuracy.



Full Needle Roller Bearings Design

The planetary gear transmission employs full needle roller bearings without retainer to increase the contact surface, which greatly upgrades structural rigidity and service life.



Collet Locking Mechanism

The input-end and the motor are coupled through a collet locking mechanism. It has passed dynamical balance analysis to assure concentricity and balance on the connection and no backlash for power transmission while running at high speed.

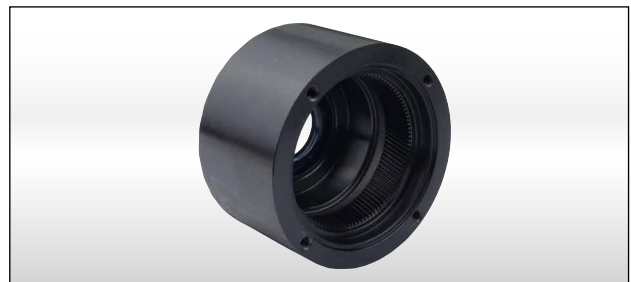

One-piece Gear Box & Advanced Surface Treatment

The gear box and internal ring gear are one-piece constructed to achieve high rigidity and high torque.

MODEL : SN

RATIO : 3, 4, 5, 7, 10 (1-Stage)

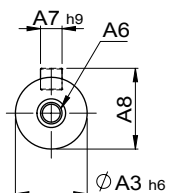

A VIEW

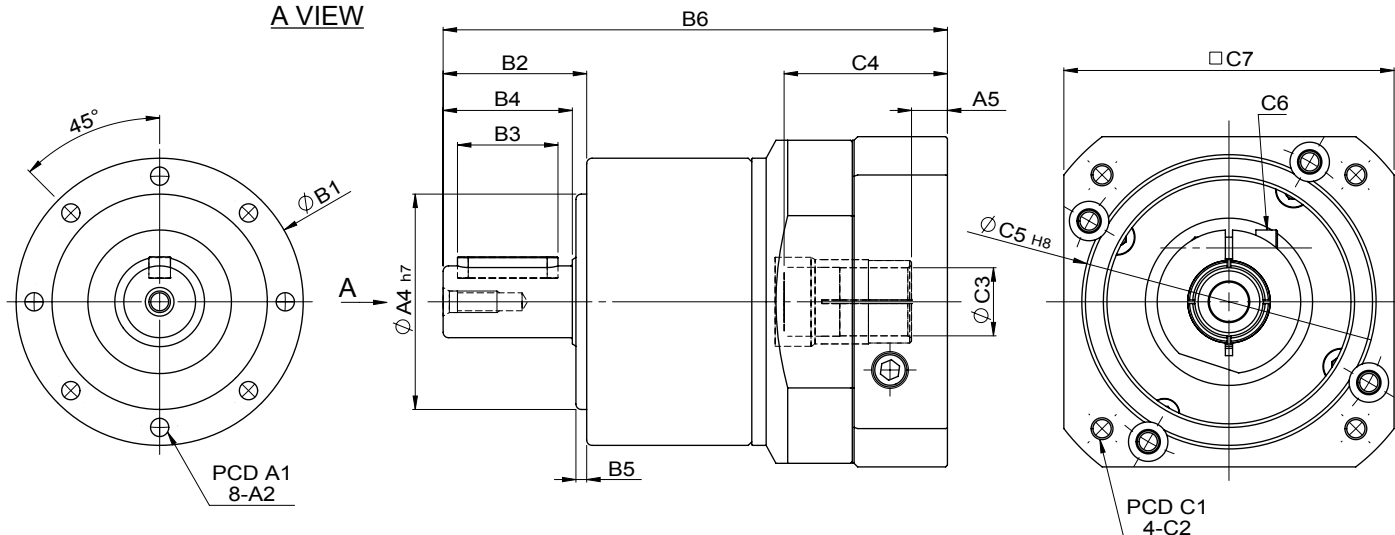

unit: mm

Model Code	50	60	70	80	90	115	120	155	160	
A	A1	44	52	62	70	80	100	108	140	145
	A2	M4 x P0.7	M5 x P0.8	M5 x P0.8	M6 x P1.0	M6 x P1.0	M10 x P1.5	M8 x P1.25	M10 x P1.5	M12 x P1.75
	A3	12	14	16	20	22	25	32	40	40
	A4	35	40	52	60	68	80	90	120	130
	A5	4.5	4.5	6	10	9·23.5	8·22.5	10	10	10
	A6	M4 x P0.7	M4 x P0.7	M5 x P0.8	M6 x P1.0	M6 x P1.0	M8 x P1.25	M12 x P1.75	M12 x P1.75	M12 x P1.75
	A7	4	5	5	6	6	8	10	12	12
	A8	13.5	16	18	22.5	24.5	28	35	43	43
B	B1	51	60	70	80	90	115	122	155	160
	B2	25.5	34	36	40	46	56	70	88	88
	B3	15	25	20	28	30	40	50	65	65
	B4	20	30	28	36	36	50	58	78	78
	B5	4	3	6.5	3	8	4	9	8	8
	B6	96.5	108	115	140.5	155.5·170	173.5·188	211·221	238.5 260.5	238.5 260.5
C	C1	45·46·48.5·63·70	45·46·48.5·63·70	70·75·90	90·100·115·145	90·100·115·145	90·100·115·145	115·145·165	115·145·165 145·165·200	115·145·165 145·165·200
	C2	M3·M4·M5	M3·M4·M5	M5·M6	M6·M8	M6·M8	M6·M8	M6·M8·M10	M6·M8·M10 M8·M10·M12	M6·M8·M10 M8·M10·M12
	C3	8·10·11·14	8·9·10·12.7·14	11·14·16·19	14·16·19	19·24	19·22·24	24·28·32	24·28·32 35·38	24·28·32 35·38
	C4	32	32	33.5	45.5	51·65.5	51·65.5	67·77	63 84.5	63 84.5
	C5	30·40·50	30·40·50	50·60·70	70·80·95·110	70·80·95·110	70·80·95·110	95·110·130	95·110·130 110·130·180	95·110·130 110·130·180
	C6	M4 x P0.7	M4 x P0.7	M5 x P0.8	M5 x P0.8	M6 x P1.0	M6 x P1.0	M8 x P1.25	M8 x P1.25 M10 x P1.5	M8 x P1.25 M10 x P1.5
	C7	46·55·60	46·55·60	70·75·80	92·110·130	92·110·130	92·110·130	122·130·150	122·130·150 146·150·190	122·130·150 146·150·190

Characteristic of SN 1-Stage SN

Model No.		Unit	Ratio	50	60	70	80	90	115	120	155	160
/ Rated Output Torque (Nominal Output Torque)	T_{2N}	Nm	3	17	28	54	112	146	165	301	553	625
			4	15	38	48	110	144	146	269	491	555
			5	14	40	45	108	140	160	278	510	618
			7	13	35	41	105	128	149	258	473	573
			10	12	25	40	100	123	141	246	452	549
/ Max. Acceleration Torque	T_{2B}	Nm	3~10	1.8 Times of Rated Output Torque								
/ Max. Output Torque / Emergency Stop Torque	T_{2NOT}	Nm	3~10	3 Times of Rated Output Torque								
/ Rated Input Speed	n_{1N}	rpm	3~10	3,000								
/ Max. Input Speed	n_{1B}	rpm	3~10	6,000					5,000			
/ Torsional Rigidity		Nm/arcmin	3~10	3	4	5	12	13	14	27	49	60
/ Max. Radial Force	F_{2RB}	N	3~10	670	1,030	1,760	2,350	2,920	3,500	6,100	8,830	9,200
/ Max. Axial Force	F_{2aB}	N	3~10	335	515	880	1,175	1,460	1,750	3,050	4,415	4,600
/ Service Life	L_H	hr	3~10	S5 Cycle Operation: >30,000 (S1 Continuous Operation: >15,000 hrs)								
/ Efficiency	η	%	3~10	$\geq 97\%$								
/ Operating Temperature		°C	3~10	-25° C ~ +90° C								
/ Lubrication			3~10	Synthetic Grease								
/ Protection Class			3~10	IP65								
/ Mounting Position			3~10	Any								
/ Noise Level		dB	3~10	≤ 58	≤ 58	≤ 58	≤ 60	≤ 60	≤ 63	≤ 63	≤ 65	≤ 65
/ Weight $\pm 2\%$		Kg	3~10	0.73	0.99	1.25	2.1	2.8	4.98	6.7	13.6	15

■ Mass Moments of Inertia (kg.cm²)

Ratio	50	60	70	80	90	115	120	155	160
3	0.03	0.06	0.15	0.48	0.55	0.60	3.01	8.14	9.21
4	0.03	0.06	0.15	0.38	0.42	0.45	2.52	6.63	7.42
5	0.03	0.06	0.13	0.38	0.42	0.45	2.52	6.63	7.42
7	0.03	0.06	0.13	0.38	0.42	0.45	2.31	6.55	7.14
10	0.03	0.06	0.13	0.35	0.38	0.41	2.30	6.46	7.03

MODEL : SN

RATIO : 15, 20, 25, 30, 35, 40, 50, 70, 100 (2-Stage)

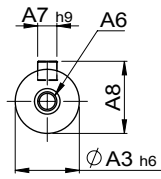

A VIEW

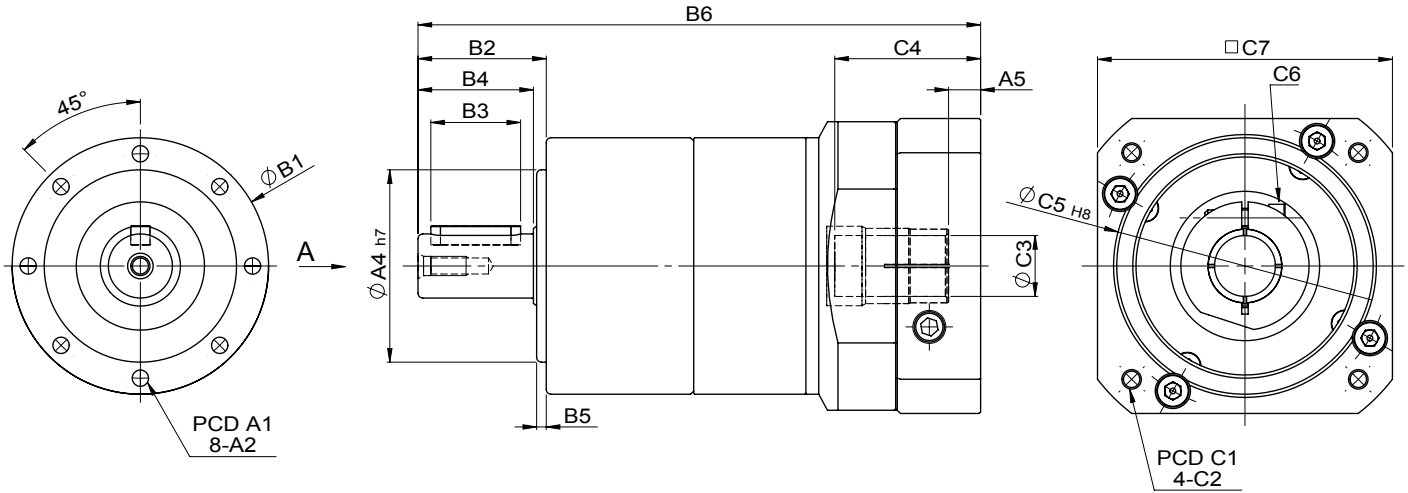

unit: mm

Model Code	50	60	70	80	90	115	120	155	160	
A	A1	44	52	62	70	80	100	108	140	145
	A2	M4 x P0.7	M5 x P0.8	M5 x P0.8	M6 x P1.0	M6 x P1.0	M10 x P1.5	M8 x P1.25	M10 x P1.5	M12 x P1.75
	A3	12	14	16	20	22	25	32	40	40
	A4	35	40	52	60	68	80	90	120	130
	A5	4.5	4.5	6	10	8.5	8 · 22.5	10	10	10
	A6	M4 x P0.7	M4 x P0.7	M5 x P0.8	M6 x P1.0	M6 x P1.0	M8 x P1.25	M12 x P1.75	M12 x P1.75	M12 x P1.75
	A7	4	5	5	6	6	8	10	12	12
	A8	13.5	16	18	22.5	24.5	28	35	43	43
B	B1	51	60	70	80	90	115	122	155	160
	B2	25.5	34	36	40	46	56	70	88	88
	B3	15	25	20	28	30	40	50	65	65
	B4	20	30	28	36	36	50	58	78	80
	B5	4	3	6.5	3	8	4	9	8	8
	B6	122.5	134	148.8	175.5	190.5 · 205	217 · 231.5	257 · 267	298.5	298.5
C	C1	45 · 46 · 48.5 · 63 · 70	45 · 46 · 48.5 · 63 · 70	70 · 75 · 90	90 · 100 · 115 · 145	90 · 100 · 115 · 145	90 · 100 · 115 · 145	115 · 145 · 165	115 · 145 · 165	115 · 145 · 165
	C2	M3 · M4 · M5	M3 · M4 · M5	M5 · M6	M6 · M8	M6 · M8	M6 · M8	M6 · M8 · M10	M6 · M8 · M10	M6 · M8 · M10
	C3	8 · 10 · 11 · 14	8 · 9 · 10 · 12.7 · 14	11 · 14 · 16 · 19	14 · 16 · 19	19 · 24	19 · 22 · 24	24 · 28 · 32	24 · 28 · 32	24 · 28 · 32
	C4	32	32	33.5	45.5	51 · 65.5	51 · 65.5	67 · 77	67	67
	C5	30 · 40 · 50	30 · 40 · 50	50 · 60 · 70	70 · 80 · 95 · 110	70 · 80 · 95 · 110	70 · 80 · 95 · 110	95 · 110 · 130	95 · 110 · 130	95 · 110 · 130
	C6	M4 x P0.7	M4 x P0.7	M5 x P0.8	M5 x P0.8	M6 x P1.0	M6 x P1.0	M8 x P1.25	M8 x P1.25	M8 x P1.25
	C7	46 · 55 · 60	46 · 55 · 60	70 · 75 · 80	92 · 110 · 130	92 · 110 · 130	92 · 110 · 130	122 · 130 · 150	122 · 130 · 150	122 · 130 · 150

Characteristic of SN 2-Stage SN

Model No.		Unit	Ratio	50	60	70	80	90	115	120	155	160
/ Rated Output Torque (Nominal Output Torque)	T_{2N}	Nm	15	17	28	54	112	146	165	301	553	625
			20	15	38	48	110	144	146	269	491	555
			25	14	40	45	108	140	160	278	510	618
			30	17	28	54	112	146	165	301	553	625
			35	13	35	41	105	128	149	258	473	618
			40	15	38	48	110	144	146	269	491	555
			50	14	40	45	108	140	160	278	510	618
			70	13	35	41	105	128	149	258	473	573
			100	12	25	40	100	123	141	246	452	549
/ Max. Acceleration Torque	T_{2B}	Nm	15~100	1.8 Times of Rated Output Torque								
/ Max. Output Torque / Emergency Stop Torque	T_{2NOT}	Nm	15~100	3 Times of Rated Output Torque								
/ Rated Input Speed	n_{1N}	rpm	15~100	3,000								
/ Max. Input Speed	n_{1B}	rpm	15~100	6,000						5,000		
/ Torsional Rigidity		Nm/arcmin	15~100	3	4	5	12	13	14	27	49	60
/ Max. Radial Force	F_{2rB}	N	15~100	670	1,030	1,760	2,350	2,920	3,500	6,100	8,830	9,200
/ Max. Axial Force	F_{2aB}	N	15~100	335	515	880	1,175	1,460	1,750	3,050	4,415	4,600
/ Service Life	L_H	hr	15~100	S5 Cycle Operation: >30,000 (S1 Continuous Operation: >15,000 hrs)								
/ Efficiency	η	%	15~100	$\geq 94\%$								
/ Operating Temperature		°C	15~100	-25° C ~ +90° C								
/ Lubrication			15~100	Synthetic Grease								
/ Protection Class			15~100	IP65								
/ Mounting Position			15~100	Any								
/ Noise Level		dB	15~100	≤ 60	≤ 60	≤ 60	≤ 62	≤ 62	≤ 65	≤ 65	≤ 67	≤ 67
/ Weight $\pm 2\%$		Kg	15~100	1.05	1.46	1.9	3.2	4.48	6.92	9.84	17	18.5

■ Mass Moments of Inertia (kg.cm²)

Ratio	50	60	70	80	90	115	120	155	160
15	0.025	0.05	0.11	0.29	0.38	0.40	2.71	7.81	8.68
20	0.025	0.05	0.11	0.29	0.38	0.40	2.29	6.27	7.08
25	0.025	0.05	0.11	0.29	0.38	0.40	2.29	6.01	6.97
30	0.025	0.05	0.11	0.29	0.38	0.40	2.71	7.81	8.65
35	0.025	0.05	0.11	0.29	0.38	0.40	2.17	5.92	6.71
40	0.025	0.05	0.11	0.29	0.38	0.40	2.29	6.27	7.08
50	0.025	0.05	0.11	0.29	0.38	0.40	2.29	6.01	6.97
70	0.025	0.05	0.11	0.29	0.38	0.40	2.17	5.92	6.71
100	0.025	0.05	0.11	0.26	0.32	0.38	2.11	5.80	6.61